

DC3000 Series

Door Closers



Applications

DC3000

DC3000 Series

Applications

The mid-priced, cost-effective choice for high-traffic situations. The DC3000 Series Door Closers fulfill security and life safety requirements by ensuring reliable latching for access control and fire code compliance, along with ease of operation and precise adjustability for barrier-free code compliance. Ideal for virtually all door openings and draft conditions in both new construction and renovations, including:

- Schools and universities
- Health care
- Government
- Commercial and industrial
- Office and retail
- Transportation and utilities
- Hotels and conference centers
- Religious

Advantages

- Meets or exceeds ANSI/BHMA A156.4 Grade 1 requirements
- Compliance with building and barrier-free codes 
- Up to full 180° door opening
- One-piece seamless steel spring tube seals in hydraulic fluid
- Tapered valves allow precise adjustment
- Cast iron body
- Quik-Install™ mounting bracket speeds installation, reducing cost and errors
- 15-year limited warranty
- UL10C, UBC
- Powder painted arms and retrofit plates

Table of Contents

Applications.....	2
Features.....	3 & 4
Mountings.....	5 & 6
Door Closer Arms.....	7 & 8
Mounting Brackets.....	9
Brackets and Covers.....	10
Size and Handing.....	11
How to Order.....	12
Quick Codes.....	13
Helpful Terms.....	14
How to Specify.....	15

Overview of Features

Features	DC3200 Closers
Spring power	Multi-sized; Adjustable 1-6
Latching speed valve	Standard
Closing speed valve	Standard
Backcheck intensity valve	Standard
Delayed action valve	Optional
Parallel arm mounting	Optional
Top jamb mounting	Optional
Hold open	Optional
Sex nuts and bolts (SNBs)	Optional
Corrosion protection	Optional
Full cover	Standard
15-year warranty	Standard
Heavy-duty regular arm	Optional
Heavy-duty parallel arm	Optional
Backstop arm	Optional

Finishes		
Old Designation	Description	Specify
USP	Primed	600
SBL	Silver Aluminum	689
LBL	Dark Bronze	690
DBL	Light Bronze	691
FBL	Black	693
GBL	Satin Brass	696

Features

DC3000

Features

Spring Power

Multi-sized; fully adjustable 1 through 6.

Handing

Non-handed.

Body

Cast iron case with seamless cold-headed steel spring tube.

Arm

Standard: forged steel. Optional arms, pages 7 and 8.

Spindle

Cold-headed heat-treated steel.

Piston

1-3/8" diameter; Precision machined, heat-treated steel.

Springs

Chrome silicon wire.

Valves

Latching speed, closing speed and backcheck intensity valves standard. Delayed action valve optional (preset for 20 seconds; between 90° and 70° for all mountings.) To order, specify M71.

Seals

"O" rings.

Fluid

Standard high lubricity extreme temperature hydraulic fluid.

Degree of Opening

Up to full 180° opening standard for regular, top jamb and parallel arm mountings, conditions permitting.

Power Adjustment Arm Bracket

15% adjustment standard.

Cover

Non-metallic full cover.

Mountings

Standard: regular arm and top jamb. Parallel arm or tri-style packaging - specify DC3210
Optional mountings; see page 6.

Mounting Bracket

Quik-Install™ mounting bracket standard.

Fasteners

Standard: self-drilling screws.
Optional: sex nuts and bolts (SNBs); Specify M54.

Corrosion Protection

Painted protective coating on all metal surfaces for use in corrosive environments. Specify M75.

Warranty

15-year limited warranty. Refer to Corbin Russwin price book for details.

Certification/Compliance



Barrier-Free Code Compliance

The DC3000 Series Door Closers listed below conform to the 5 lbf. maximum door opening force requirement for non-fire-rated interior hinged doors, according to:

Americans with Disabilities Act (ADA)

Complies with the Accessibility Guidelines for Buildings and Facilities, Section 4.13.11.

ANSI/BHMA Certified

A156.4, Grade 1.
A117.1.

UL / ULC / UL10C

Listed for fire and cycle requirements.

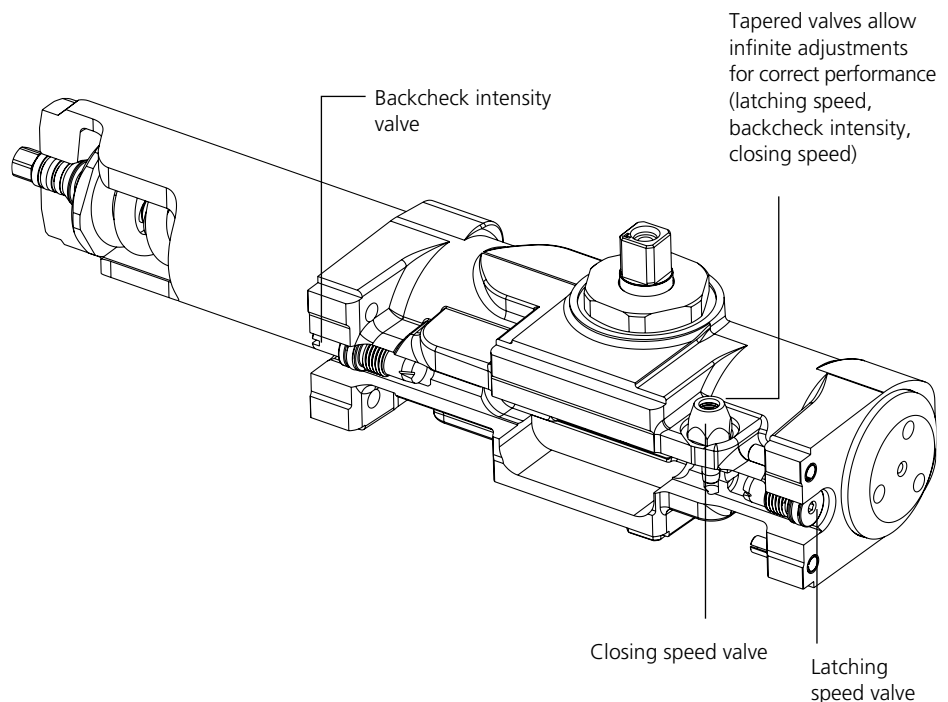



DC3200 Regular Arm Mounting

- Most common mounting, providing the greatest closing efficiency
- Closer is mounted on the pull side, with the arm perpendicular to the face of the door
- Arm bracket is attached to the door frame



DC3210 Parallel Arm Mounting

- Allows inside application of closer on out-swinging doors
- Closer is mounted on the push side, with the arm parallel to the face of the door
- Arm does not project from the opening



DC3220 Top Jamb Mounting

- Accommodates reveals up to 3-1/4" (83mm)
- Closer is mounted on the push side, with the arm perpendicular to the face of the door
- Arm bracket is mounted on the door
- Minimum 1-3/4" (44mm) top jamb required

Mountings

DC3000

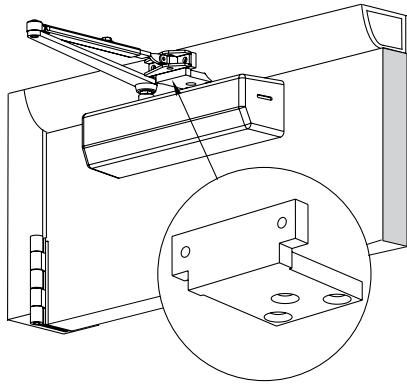

Regular Arm Mounting with Mortise Arm Bracket

Used on inadequately reinforced frames, such as those with bull nose trims.

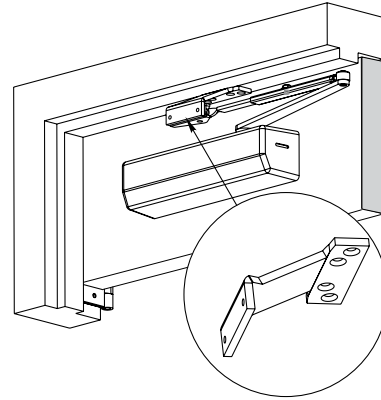

Parallel Arm with Offset Angle Bracket Mounting

Allows parallel arm mounting when used with an overhead door holder.

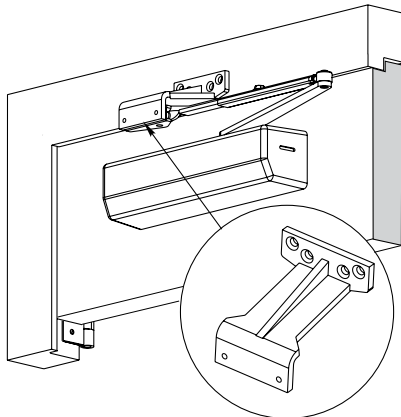

Parallel Arm Mounting with Flush Transom Bracket

Allows parallel arm mounting on flush transom applications.

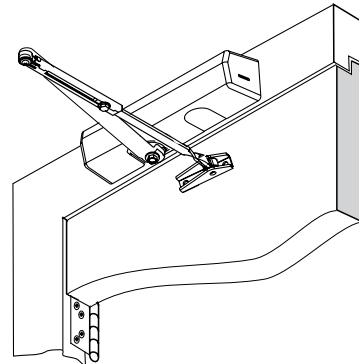

Top Jamb Flush Transom Mounting

Closer is top jamb mounted on the push side; arm is attached to the door.

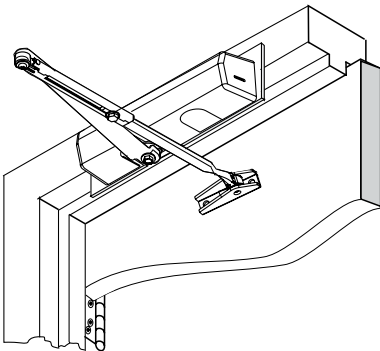

Narrow Frame Mounting

For use when the frame is too narrow for a normal top jamb or top jamb track mounting. (Shown with 188F65 drop plate)

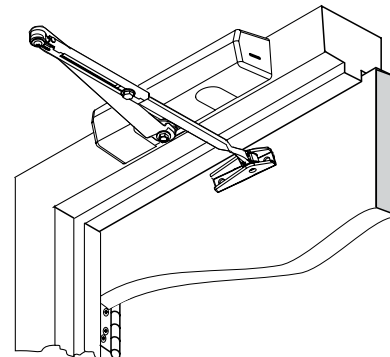

Top Jamb Deep Reveal Mounting

For reveals greater than 3-1/4" (83mm), up to 7-1/4" (184mm).

Door Closer Arms

DC3000

**688F95
(Non-Hold Open)**



**688F77
(Hold-Open)**



Regular Arm

- Used with regular arm mounting (pull side) and top jamb mounting (push side)
- Non-Hold Open arm standard on the DC3200
- Hold Open arm optional, specify closer x **A1***

**597F52
(Non-Hold Open)**



Heavy-Duty Regular Arm

- Recommended for high-use, high-abuse environments
- Tamper-resistant, solid forged steel riveted arm
- Mounted on pull side
- Optional on DC3200 closer, specify closer x **A10**

**688F95 x 188F41
(Non-Hold Open)**



Parallel Arm

- Mounted on push side
- Non-Hold Open arm combines regular arm with parallel arm mounting bracket
- Hold Open arm combines regular hold open arm with parallel arm mounting bracket
- Non-Hold Open arm standard on the DC3210
- Hold Open arm optional, specify closer x **A1***

**688F77 x 509F49
(Hold Open)**



*Not allowed by code on fire doors.

Door Closer Arms

DC3000

688F95 (Non-Hold Open)

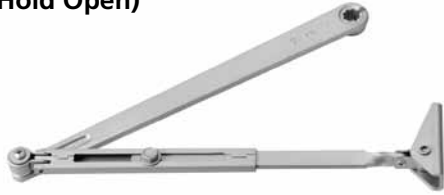

Top Jamb

- Used with top jamb mounting (push side); for reveals up to 3-3/4" (95 mm)
- Non-Hold Open arm standard on the DC3220
- Hold Open arm optional, specify closer x **A1***

688F77 (Hold Open)



689F02 (Non-Hold Open)

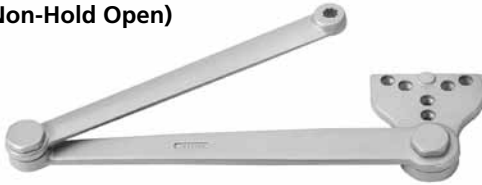

Heavy-Duty Parallel Arm

- Recommended for high-use, high-abuse environments
- Tamper-resistant, solid forged steel riveted arm
- Mounted on push side
- Optional on DC3210 closers
- Non-hold open arm, specify closer x **A3**
- Hold open arm, specify closer x **A2***. Hold-open range 85° to 110°

689F01 (Hold Open)



689F03 (Non-Hold Open)



Heavy-Duty Reversible Backstop Parallel Arm

- Recommended for high-use, high-abuse environments
- Tamper-resistant, solid forged steel riveted arm (mounted on push side)
- Field-reversible steel lug restricts degree of opening to protect door, wall and hardware
- Requires both backcheck valves on closer
- Shipped standard as left hand. Handing can be reversed in the field
- Optional on DC3210 closers
- Non-hold open arm, specify closer x **A4**. Door stop range 85° to 110°
- Hold open arm, specify closer x **A5***. Door stop/hold open range 85° to 110°

689F04 (Hold Open)



Mounting Brackets

DC3000

188F03



Quik-Install™ Mounting Bracket

- Standard on all closers
- Reduces installation time
- Ensures correct mounting
- Bracket is first mounted to door or frame, then closer is attached
- Bracket size: 1-3/4" (44mm) (vertical) x 6" (152mm) (horizontal)
- Hole spacing: 1" (25mm) (vertical) x 4-5/16" (110mm) (horizontal)

244F17



Mortise Arm Bracket for Regular Arm Mounting

- For regular arm mounting where frame requires reinforcement, i.e., on frames with bull nose trim
- Specify closer x M84

188F41



Parallel Arm Non-Hold Open Bracket

- Converts regular arm to parallel arm closer
- Standard with parallel arm mounting
- Packed with five screws and 691F78 spacer

509F49



Parallel Arm Hold Open Bracket

- Converts regular arm hold open to parallel arm hold open closer
- Standard with parallel arm hold open mounting

188F62



Parallel Arm Offset Bracket

- Required when parallel arm is used in conjunction with an overhead door holder
- Specify closer x M83

188F63

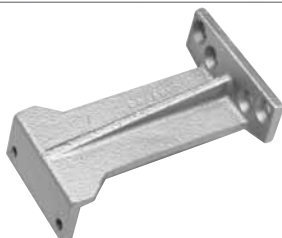

Parallel Arm Flush Transom Bracket

- Required when parallel arm mounting is used on a flush transom application
- Not available in plated finishes
- Specify closer x M82

Specify finish when ordering parts.

Brackets and Covers

DC3000



Drop Plate (Option M80)

Permits parallel arm or top jamb mounting on door when top rail is too narrow to install closer in the regular manner. Minimum 2" top rail required. Optional on DC3000 closers; see Quick Codes, page 13. To order separately, specify drop plate number x Finish

Closer Series	Drop Plates
	Full Cover
DC3210	597F58
DC3220	188F65

Maximum Power



Normal Power



Power Adjustment Arm Bracket

Standard on all closers without hold open. In regular arm or top jamb mounting, bracket may be reversed to increase closing power 15%.

447F14

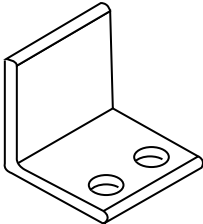

Angle Support Bracket and Spacer

- Available separately for mounting of A2, A3, A4 and A5 heavy-duty arms on narrow frame or soffit conditions
- Specify closer x M85

597F78



Full Cover

- Standard on all DC3000 series door closers
- Completely covers closer body
- Non-handed
- Dimensions: 11-5/8" (295mm) x 3" (76mm) x 2-3/4" (70mm) deep

Factors in Determining Closer Size

1 - Weight and Height of Door

Doors vary in weight from light hollow-core wood doors to heavy metal doors. Door sizes listed in the chart are based on doors of standard weight and height. Extra-light or extra-heavy weight or unusual height must be compensated for.

2 - Draft and Wind Conditions

Draft and wind conditions are perhaps the most important factors to consider in determining the closer size required. Sizes listed in the chart apply to normal conditions. Stairwells, air conditioning, building construction, and door location can cause strong draft and wind conditions; these may necessitate adjusting spring power to a larger size or using a closer one size larger.

3 - Code Compliance

A multi-sized, fully adjustable closer such as the DC3200 closer provides the greatest flexibility in balancing barrier-free access, security and life safety codes. However, when a manual closer is installed and adjusted to comply with ADA or any other reduced opening force requirements, it may no longer have sufficient power to close and latch the door reliably.

Mounting	Recommended Door Closer Sizes			Recommended Closer Size Adjusted
	Size Of Door			
	Interior	Exterior In-swinging	Exterior, Out-swinging	
Regular or Top Jamb	2'4"	-	-	1
	3'0"	-	-	2
	3'6"	2'6"	3'0"	3
	4'0"	3'0"	3'6"	4
	4'6"	3'6"	4'0"	5
	5'0"	4'0"	4'6"	6
Parallel Arm	2'4"	-	-	1
	2'6"	-	-	2
	3'0"	-	2'6"	3
	3'6"	-	3'0"	4
	4'0"	-	3'6"	5
	4'6"	-	4'0"	6

Handing

Refers to the direction a door swings; always determined from the outside of the door.

Regular Mounting

Door: left hand
Closer: left hand pull side

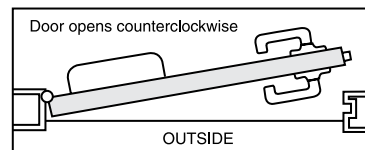

Door: right hand
Closer: right hand pull side

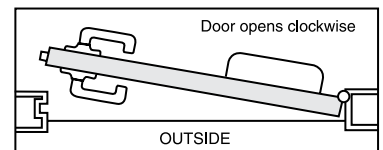

Parallel Arm Mounting

Door: left hand reverse bevel
Closer: right hand push side

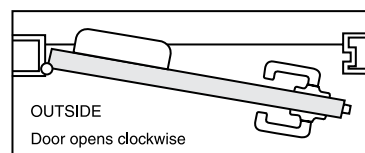

Door: right hand reverse bevel
Closer: left hand push side

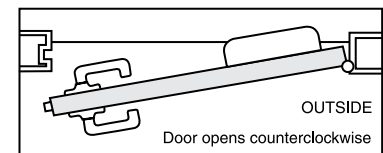

Top Jamb Mounting

Door: left hand reverse bevel
Closer: right hand push side

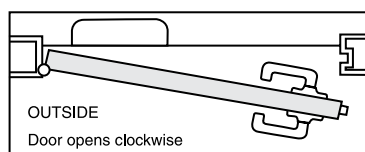

Door: right hand reverse bevel
Closer: left hand push side

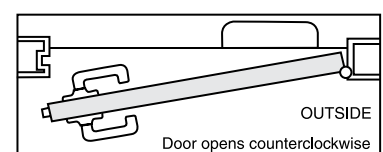

How to Order

DC3000

ANSI/BHMA A156.4 Certified Closer Cross Reference

ANSI/BHMA Number	Function	Series	PT 4A 15% Power Adjustment	PT 4B 35% Power Adjustment	PT 4C 50% Power Adjustment	PT 4D Adjustable Backcheck	PT 4F Delayed Action PT	4G Dead Stop PT	4H Fully Adjustable
CO2011 (PT1)	Hinge Side Mounting	DC3200	S	S	S	S	O	N/A	S
CO2051 (PT1)	Hinge Side Mounting Holder Arm	DC3200-A1	S	S	S	S	O	N/A	S
CO2021 (PT1)	Parallel Arm Mounting	DC3210	S	S	S	S	O	O	S
CO2061 (PT1)	Parallel Arm Mounting Holder Arm	DC3210-A1	S	S	S	S	O	O	S
CO2041 (PT1)	Top Jamb Mounting	DC3220	S	S	S	S	O	N/A	S
CO2081 (PT1)	Top Jamb Mounting Holder Arm	DC3220-A1	S	S	S	S	O	N/A	S
CO2191 (PT1)	Drop Plate for Frames or Narrow Top Rail Doors	DC3220 w/ 188F65	S	S	S	S	O	N/A	S
CO2201 (PT1)	Drop Plate for Parallel Arm Mounting on Narrow Top Rail Doors	DC3210 w/ 188F65 or 597F58	S	S	S	S	O	O	S

ANSI Performance Requirements: (PT 1)- 2,000,000 cycles
N/A = not available S = standard O = option available

Ordering Examples

Stock Order		
Quantity	Series	Finish
50	DC3200	689

Contract Order						
Quantity	Series	Arm	Finish	Hand	Door Thickness	Misc. Options
150	DC3220	A1	690	RH	D138	M54

Consult factory if door weight exceeds 250lbs.

Quick Codes

DC3000

Series/Mounting/Size		
Description	Mounting	Specify
DC3200 Closers Multi-sized; full adjustability from size 1-6	Regular Arm	DC3200
	Parallel Arm	DC3210
	Top Jamb	DC3220

Arm	
Description	Specify
Regular non-hold open	(standard)
Hold open	A1*
Heavy-duty parallel with hold open	A2*
Heavy-duty parallel non-hold open	A3
Heavy-duty backstop non-hold open	A4
Heavy-duty backstop with hold open	A5*
Heavy-duty regular non-hold open	A10

* Hold Open arms cannot be used on fire doors.

Handing	
Hand	Specify
Right Hand/Left Hand Reverse	RH
Left Hand/Right Hand Reverse	LH

Finish	
Description	Specify
USP Primed for Painting	600
SBL Silver Aluminum Painted	689
LBL Dark Bronze Painted	690
DBL Light Bronze Painted	691
FBL Black Painted	693
GBL Satin Brass Painted	696

Door Thickness	
Door Thickness	Specify
1-3/4" (44mm)	(standard)
2" (51mm)	D200
2-1/4" (57mm)	D214

Miscellaneous Options	
Description	Specify
Sex nuts and bolts (SNBs) (1-3/4" minimum thickness)	M54
Delayed action	M71
Full cover	(standard)
Corrosion protection	M75
Heavy-duty parallel arm flush transom bracket (499F30) used with A2, A3, A4, A5 arms	M79
Parallel arm flush transom bracket (parallel or A1)	M82
Parallel arm offset bracket	M83
Mortise arm bracket (for regular arm mounting)	M84
Angle support bracket	M85
Extreme temperature fluid	(standard)

Drop Plates - order by number (formerly M80)	
Closer Series	Drop Plate
DC3210 (parallel)	597F58
DC3220 (top jamb)	188F65

Paint (cans)	
Description	Specify
Silver Aluminum	597F94
Dark Bronze	597F95
Light Bronze	597F96
Satin Brass	597F97

Helpful Terms

DC3000

Arm

The linkage of a closer that connects the body to the door or frame.

Backcheck

Slows a door during the opening cycle, by providing cushioned resistance to a forceful opening. Designed to protect people and objects behind the door and to prevent damage to the closer, hardware, and wall. Intensity can be increased or decreased. Not intended to act as a stop.

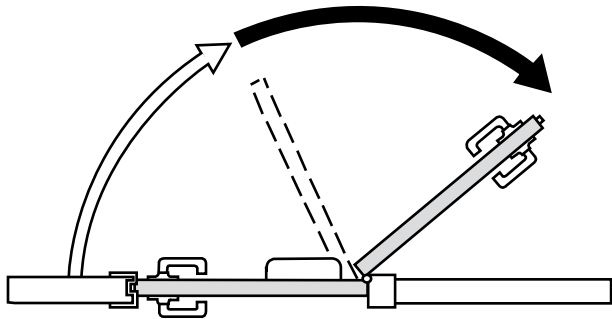

Closing Speed

The speed at which a door swings from the open position to within a few degrees of latching. See Latching Speed.

Corrosion Protection

Additional painted covering on all external parts to deter oxidation and corrosion.

Door Stop

A device to stop the swing of a door.

Hold Open

Maintains door at a particular degree of opening. A mechanical hold open may not be used on labeled fire doors, which must be self-closing.

Latching Speed

The speed of the door during the last few degrees of closing. Allows latching and prevents slamming.

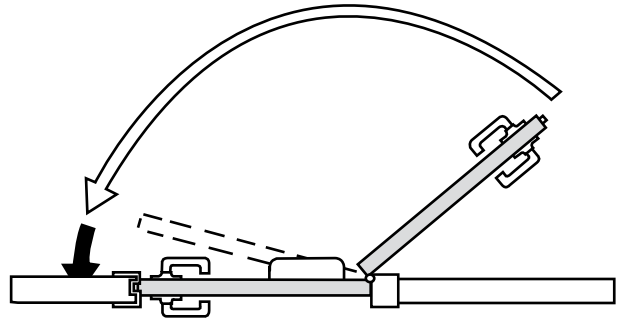

Mounting

The method by which a closer is attached to the door and frame.

Multi-Sized Closer

A closer whose spring tube design allows full adjustment of the spring power size from 1 through 6.

Quik-Install™ Mounting Bracket

Unique bracket that simplifies installation and minimizes installer fatigue.

Sex Nuts and Bolts (SNBs)

Thru-bolts required for all non-steel-reinforced fire doors, and recommended for non-reinforced wood and mineral core doors.

Spring Power

A measurement of closing force, or the ability to overcome draft, air pressure, weight or other resistance to door closing.

Star Punch

An eight-sided socket hole in the closer arm, permitting spindle pre-loading. Provides full functioning of backcheck and delayed action valves, and additional closing force, on parallel arm mountings.

Universal Mounting

The ability of a closer to accommodate either hand of door for regular, top jamb or parallel arm mounting.

Suggested Specifications

All door closers shall be DC3000 Series Door Closers as manufactured by Corbin Russwin Architectural Hardware.

Closers shall be of rack and pinion construction with a triple heat treated cold-formed steel spindle and a steel piston, heat treated and precision machined. Cases shall be of cast iron with a one-piece seamless forged spring tube. A two-piece or seamed spring tube shall not be acceptable. Springs shall be double heat treated and tempered. Closers shall have a heavy-duty, forged steel main arm.

Optional arms shall include parallel, hold open, heavy-duty, heavy-duty hold open, heavy-duty reversible backstop and heavy-duty reversible backstop with hold open.

Closers shall be multi-sized with adjustable spring power to accommodate sizes 1 through 6 in one closer body, such as the Corbin Russwin DC3200 closer. Closing shall be controlled by two valves - one to control closing speed and one to control latching speed. Valves shall be concealed against unauthorized adjustment and shall be non-critical with "O" rings.

Closers shall be available with an adjustable backcheck intensity valve. Delayed action shall be available and accomplished with a separate valve. Valves shall be accessible without removing the closer from the door.

Closers shall be surface applied with rectangular cover, and shall be devoid of manufacturer's trademarks.

Closers shall not project over 2-3/4", and shall be capable of mounting on a 1-3/4" top rail (or top jamb for inverted mounting). Full cover shall be standard. Non-hold open closers shall be regularly furnished with a power adjustment arm bracket capable of providing a 15% power adjustment. A Quik-Install™ mounting bracket to attach the closer shall be regularly furnished. High lubricity hydraulic fluid shall be furnished. Closers mounted top jamb and parallel arm shall allow for full 180° door opening.

Closers shall be listed by Underwriters' Laboratories for closers with non-hold open arms.

Certification:
ANSI/BHMA A156.4, Grade 1

ICC/ANSI A117.1
Closers shall carry a 15-year limited warranty.



ASSA ABLOY

In U.S.

Corbin Russwin
Architectural Hardware
225 Episcopal Road
Berlin, CT 06037
Phone: 800-543-3658
Fax: 800-447-6714
www.corbinruswin.com

In Canada

ASSA ABLOY Door
Security Solutions Canada
160 Four Valley Drive
Vaughan, Ontario
Canada L4K 4T9
Phone: 800-461-3007
Fax: 905-738-2478
www.assaabloy.ca

For more information regarding Corbin Russwin Locksets, Exit Devices, Door Controls and Key Systems, contact your authorized Corbin Russwin Distributor or Sales Representative.

Corbin Russwin and Design® is a registered trademark of Corbin Russwin, Inc., an ASSA ABLOY Group company. Quik-Install™ is a trademark of Corbin Russwin, Inc., an ASSA ABLOY Group company. Other products' brand names may be trademarks or registered trademarks of their respective owners and are mentioned for reference purposes only. These materials are protected under US copyright laws. All contents current at time of publication. Corbin Russwin, Inc., an ASSA ABLOY Group company, reserves the right to change availability of any item in this catalog, its design, construction, and/or its materials. Copyright © 2001, 2013 Corbin Russwin, Inc., an ASSA ABLOY Group company. All rights reserved. Reproduction in whole or in part without the express written permission of Corbin Russwin, Inc. is prohibited.

ASSA ABLOY is the global leader in door opening solutions, dedicated to satisfying end-user needs for security, safety and convenience.